

Simplan - fwd seal

General description

- Mechanical face seal for water-lubricated stern tubes
- Silicon carbide sealing ring material: corrosion- and wear-resistant
- Equipped with an additional inflatable static seal (Pneumostop)
- No wear to the shaft
- State-of-the-art environmentally friendly sealing solution
- Certified by all major classification societies

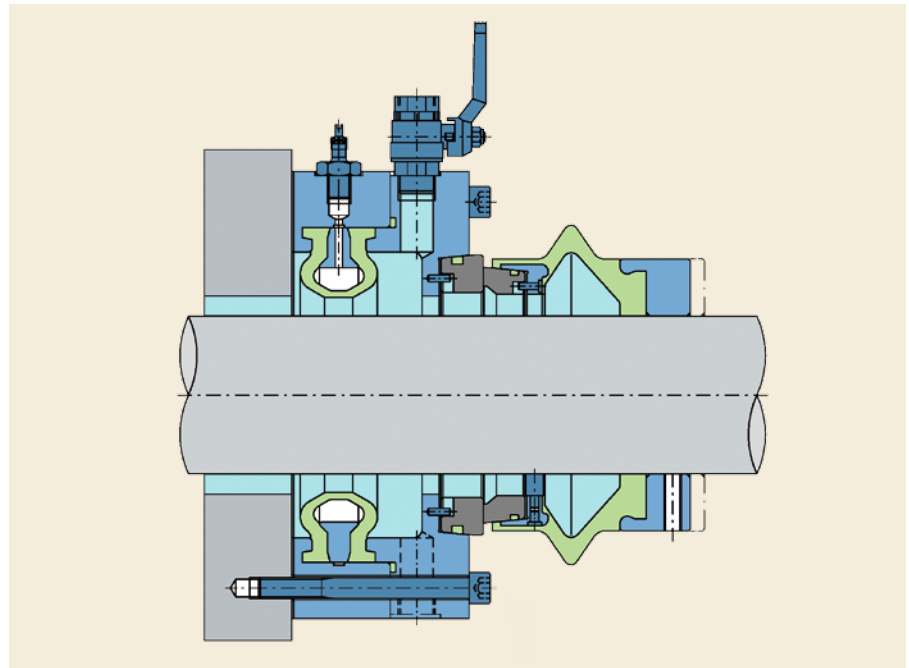

Advantages

Design

- Sealing rings made of silicon carbide (SiC)
 - harder than sand
 - extremely wear-resistant
- Pneumostop from neoprene
 - excellent mechanical properties

Installation

- Delivered fully assembled and tested
 - easy installation by the shipyard

Operation

- No wear to the shaft
 - practically maintenance-free
- Easy handling
 - reduced risk of operating failure

- Constant sealing pressure by pressure body → absorbs radial and axial shaft movements
- Proven long product life

Service

- Designed for in-situ overhaul as per certified and approved Simplex repair standards
- Worldwide service network and availability of spares

Application: Aluminium design

- Extruded aluminium housing rings
 - high tensile strength and homogeneous material, no cavities

- High resistance against seawater corrosion
- Approx. 40% lighter than the bronze version



The Original

Functional principle

LWL = Load water line
PI = Pressure indicator

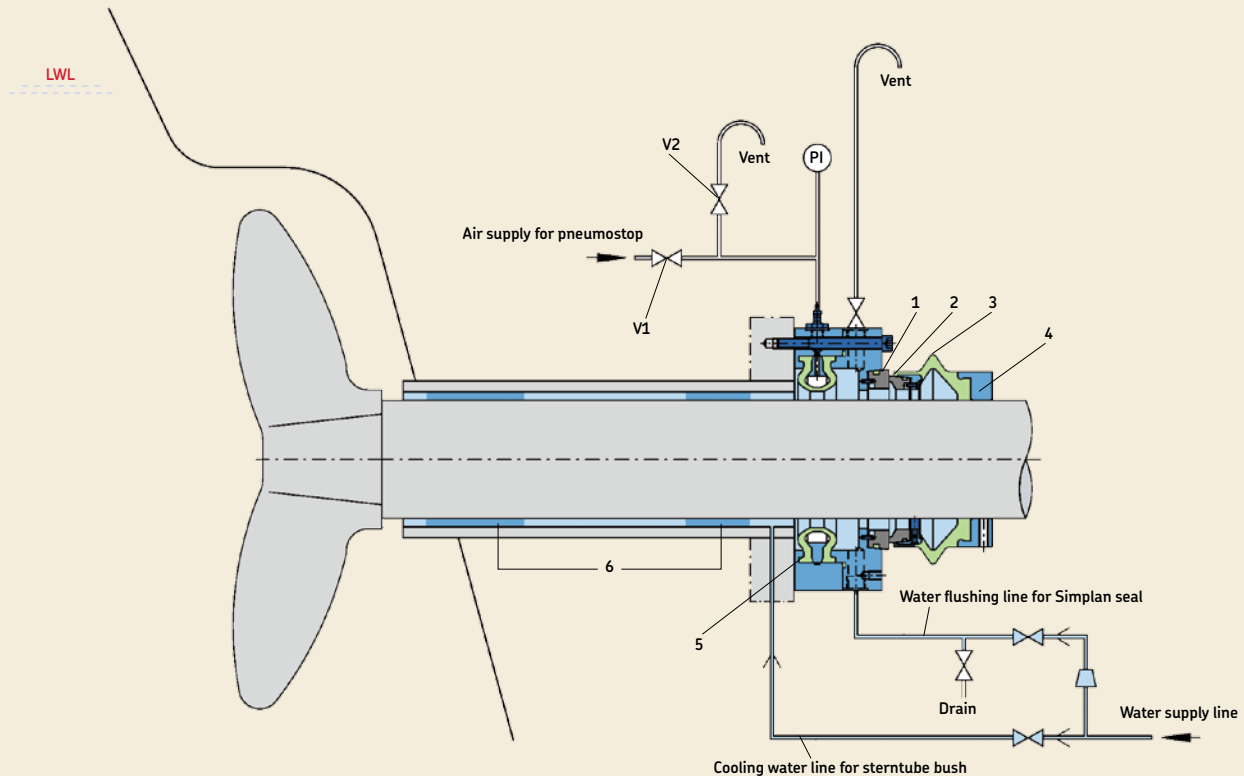

Function

- A stationary ring (1) and a rotating sealing ring (2) form the axial seal.
- The rotating sealing ring is fixed to a rubber pressure body (3).
- This pressure body is held on the shaft by a clamp ring (4) and is pre-loaded to ensure the necessary contact pressure between the stationary ring (1) and the rotating sealing ring (2).
- The Pneumostop is an inflatable tube ring (5) and operates as a static seal only.
- This Pneumostop can be inflated by an air supply line (V1 open, V2 shut).
- A supply line provides the sterntube bushes (6) with a constant supply of fresh water.
- A small amount of fresh water is needed for flushing the permanently vented seal chamber.
- During operation, the Pneumostop is always vented (V1 shut, V2 open).

SKF Marine GmbH

Hermann-Blohm-Straße 5
20457 Hamburg, Germany
sales@skf-marine.com

skf.com | skf-marine.com

© SKF and Simplex are registered trademarks of the SKF Group.

© SKF Group 2016
The contents of this publication are the copyright of the publisher and may not be reproduced (even extracts) unless prior written permission is granted. Every care has been taken to ensure the accuracy of the information contained in this publication but no liability can be accepted for any loss or damage whether direct, indirect or consequential arising out of the use of the information contained herein.

PUB 43/P2 15476/2 EN · April 2016

Certain image(s) used under license from Shutterstock.com.

Authorised Distributor



t: +44 1264 860186

e: spares@simplexturbulo.com

STC is a member of

